

(No Model.)

2 Sheets—Sheet 1.

W. FRECH.

TOOL HOLDING ATTACHMENT FOR LATHES.

No. 329,447.

Patented Nov. 3, 1885.

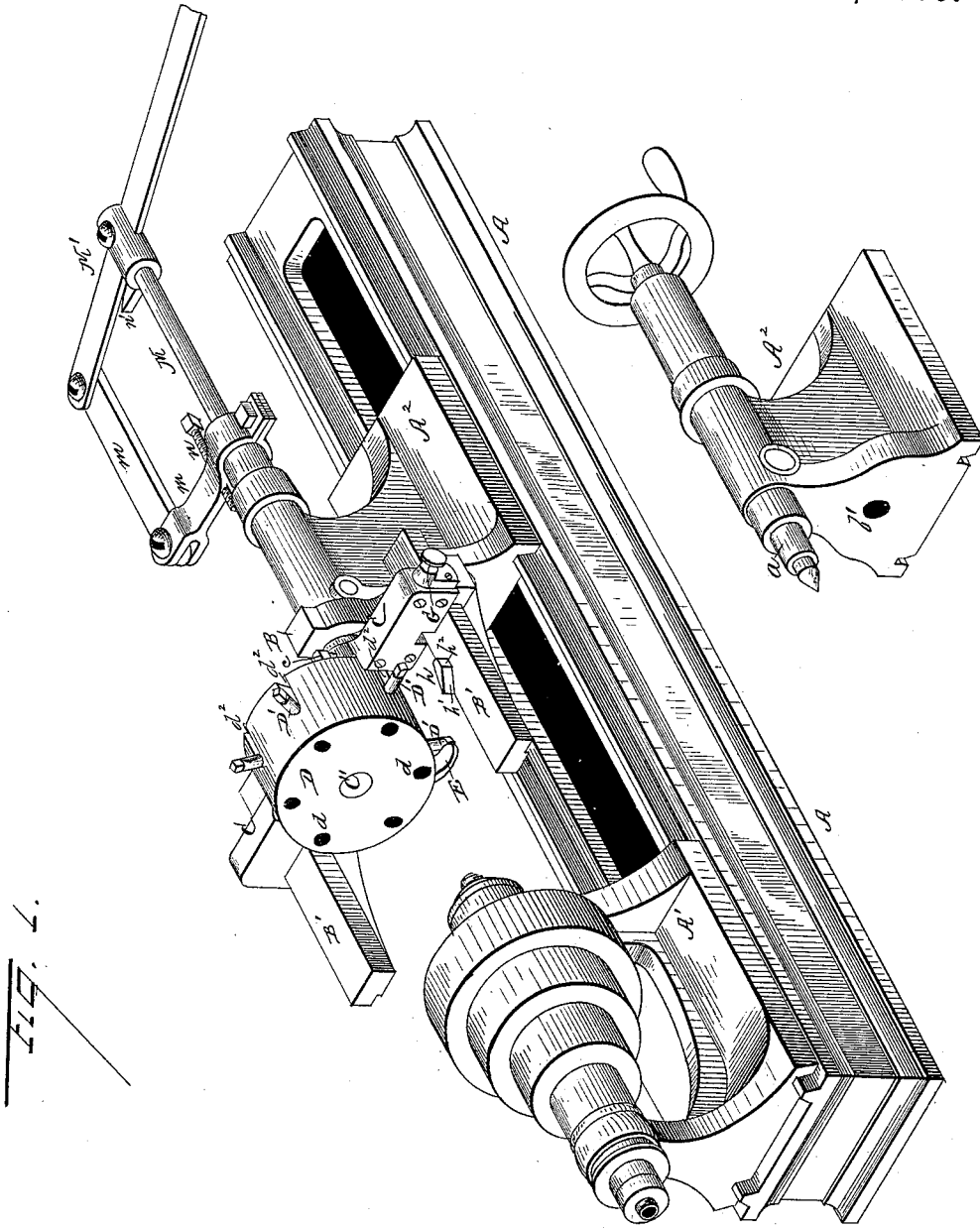

Witnesses:
M. C. McArthur.
Y. Stratton

Inventor,
William Frech
per
H. Harrison
Attorney.

(No Model.)

2 Sheets—Sheet 2.

W. FRECH.

TOOL HOLDING ATTACHMENT FOR LATHES.

No. 329,447.

Patented Nov. 3, 1885.

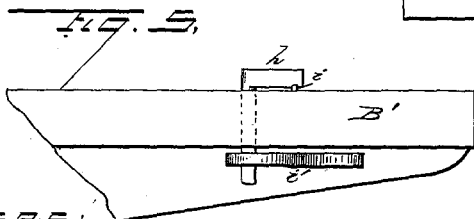
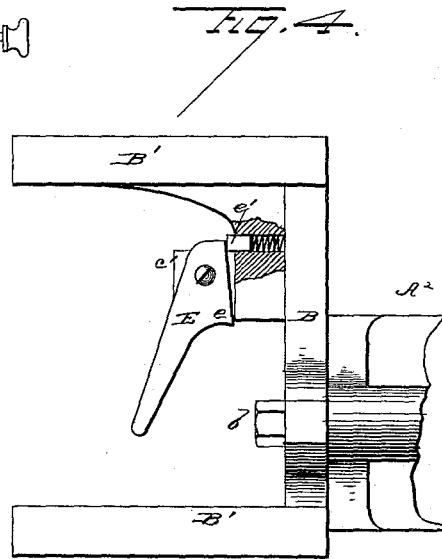
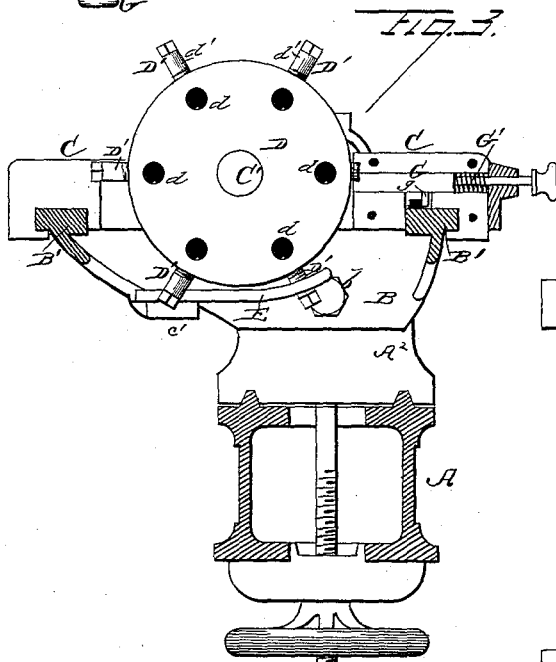
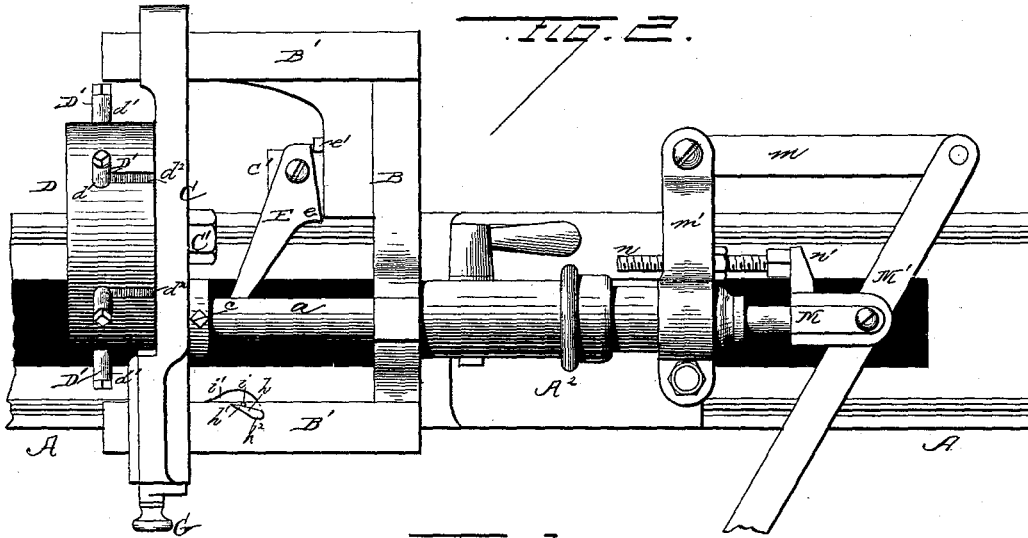

WITNESSES:

H. C. [unclear]
H. Stratton

Inventor,
William Frech

per *H. Harrison*
Attorney,

UNITED STATES PATENT OFFICE.

WILLIAM FRECH, OF CHICAGO, ILLINOIS.

TOOL-HOLDING ATTACHMENT FOR LATHES.

SPECIFICATION forming part of Letters Patent No. 329,447, dated November 3, 1885.

Application filed July 30, 1884. Serial No. 139,192. (No model.)

To all whom it may concern:

Be it known that I, WILLIAM FRECH, a citizen of the United States, residing at Chicago, in the county of Cook and State of Illinois, have invented certain new and useful Improvements in Automatic Vertical Turret-Heads for Lathes, of which the following is a specification, to wit:

This invention relates to an improvement in automatic vertical turret-heads for lathes; and it consists in certain peculiarities of the construction and arrangement of the head and its operating mechanism, substantially as will be hereinafter more fully set forth and claimed.

In order to enable others skilled in the art to which my invention appertains to make and use the same, I will now proceed to describe its construction and operation, referring to the accompanying drawings, in which—

Figure 1 is a perspective view of a lathe having my invention attached to its tail-stock, the tail-stock as ordinarily used being shown detached in the same figure; Fig. 2, a plan view of the turret-head and tail-stock; Fig. 3, a front elevation of the same. Fig. 4 is a detail view of the device for operating the head, and Fig. 5 is a detail of the pawl which operates the locking device of the head.

A represents a lathe-bed of the ordinary and well-known form, having a head-stock, A', and tail-stock A², as usual, both of which are adjustable upon the bed in the ordinary manner.

Turret-heads are usually secured in a horizontal-position upon a stock or frame which takes the place of the tail-stock, and I desire to arrange the head upon the usual tail-stock found upon all lathes, and do this in the following manner: I provide a small frame, B, clamped or secured upon the tail-stock by a single bolt, b, entering a hole, b', in the face of the stock, as shown. This frame is formed with two forwardly-projecting arms or ways, B' B', upon which slides a cross-head, C, the outer ends of which clasp the ways B' upon all sides, as fully seen in Fig. 3, and thus move firmly and accurately, without any tendency to twist, and retain the dies in proper alignment with their work, as will be presently seen. This cross-head is secured to the spindle a of the tail-stock by means of a set-screw,

c, and is moved backward and forward by this spindle during the operation of threading or screw-cutting, as hereinafter more fully described. Pivoted upon a horizontal bolt or shaft, C', of the cross-head is the turret-head D, preferably of circular form, and provided with a series of sockets or holes, d, passing through it near its periphery, in which the dies are clamped by set-bolts D', passing through the sides of the head, as shown in the drawings. These bolts project from the head a short distance, and are each formed with a short section, d', free from screw-threads, which serve to engage a hinged arm, E, to operate the head at proper times in its movement. This arm E is hinged upon an offset, e', of the frame B, below the turret, and projects forward and across the machine a sufficient distance to engage one of the lower screw-pins or set-bolts, D', upon the backward motion of the cross-head, the hinged arm being formed with a shoulder, e, engaging the main portion of the frame at this time, and holding it firm while the pressure of the projecting pin is upon it. Behind the rear end of the hinged arm E is a spring-actuated pin, e', socketed into and projecting from the frame B, and this spring-pin allows the free forward motion of the arm during the corresponding motion of the cross-head and turret, while it at once returns the arm to position when released. The outer side of the turret-head is formed with a series of notches or recesses, d², corresponding in number and location with the die-receiving sockets, and with these notches engages a catch, G, actuated by a spring, G', and socketed into one of the arms of the cross-head, as fully seen in Fig. 3. The cross-head is at this point formed on its under side with a notch, b², and a small arm, g, projects into this notch from the spring-catch G, which lies just above it. Upon the way or guide-arm B' is a hinged pawl, h, the outer end of which lies against a stop pin or projection, i, of the way. The pawl is wedge-shaped on its point, as at h', and has a short straight portion, h², near its heel, for a purpose presently seen. The shaft h² of this pawl passes through the way B', forming a pivot upon which the pawl turns, and is on its lower end furnished with a spring, i', to return

it to position after operation. The hand-wheel used upon the rear end of the spindle *a* of the tail-stock is removed for using the attachment, and a small rod or shaft, *M*, substituted, in the outer end of which is fulcrumed the operating-lever *M'*, the end of which is connected by a link, *m*, with a projection or arm, *m'*, clamped upon the tail-stock, as in Fig. 1. This arm is provided with a bolt or screw, *n*, against which strikes a stop-lug, *n'*, on the rod *M*, and serves to limit the sliding motion of the device.

But a minute is required to attach the device in the manner described to the tail-stock of a common lathe, and it is then ready for use in cutting screw-threads, either outside or inside dies being clamped in the head, as may be desired. In the position shown in Fig. 1 the head is held by the spring-catch, with one of its dies in line with the work to be operated upon, which is secured in the head-stock in the usual way. The cross-head is now pushed forward by the operating-lever, its arms passing over the pawl *h*, which is turned aside and springs back to place at once. The turret-head in passing forward during this motion engages and turns the outer end of the hinged arm *E*, which is also at once returned to place after being released. Upon the backward motion of the cross-head the point of the pawl *h* passes behind the arm *g* of the spring-catch and draws it back to release the head. The set-pin *D'* on the lower side of the head now engages the inclined arm *E*, and sliding along this arm turns the head, the catch *G* being held back by the straight portion of the pawl *h* till the head is started, and is then released, bearing against the head till it again falls into one of its notches and locks the turret with the next die in position. This operation is repeated till all, or as many as desired, of the dies have been used, and a new piece of work is then placed in position to be operated upon. It will thus be seen that any one or all of the dies may be used at will, and the turret may be set at any point by simply drawing back the catch *G* and turning the head by hand.

By applying the attachment to the usual tail-stock much expense is saved, and the device is greatly simplified by attaching the turret in the position shown, thus saving much of the operating mechanism and causing it to project its dies directly forward in a line with the head-stock.

Having thus fully described my invention, what I claim as new, and desire to secure by Letters Patent, is—

1. The combination, with the tail-stock of a lathe, of a turret-head pivoted thereon, and means, substantially as described, for automatically turning it as it is moved to and from the work, substantially as and for the purpose set forth.

2. The combination, with the tail-stock of a lathe, of a guide-frame secured to the stock, a cross-head sliding thereon and secured to the spindle of the tail-stock, a turret-head pivoted upon the cross head, socketed for the reception of the dies, and provided with screws for clamping the dies which project from the side of the turret, a spring-catch engaging notches in the turret to hold it in position, a dog on the guide-frame for withdrawing the catch, and an incline on the guide-frame to engage and automatically turn the turret, substantially as and for the purpose set forth.

3. A turret-head for lathes, formed with sockets for receiving the dies, and provided with projecting set-screws for securing them in place, in combination with an incline or arm on the frame *B*, against which the projecting screws strike to revolve the head, substantially as and for the purpose set forth.

4. In a screw-cutting attachment for lathes, the turret-head *D*, formed with sockets *d*, the set-bolts *D'*, having a short plain portion, *d'*, and the cross-head *C*, sliding on guides or ways to and from the work, in combination with the hinged and inclined arm *E*, having a shoulder, *e*, and the spring-pin *e'*, socketed in the frame and bearing against the arm, substantially as and for the purpose set forth.

5. The frame *B*, removably clamped to the tail-stock of a lathe, having guides *B'*, provided with a pivoted spring-pawl, *h*, in combination with a cross-head sliding upon said ways, and a pivoted turret-head, *D*, thereon, formed with notches on its periphery, and the spring-catch *G*, having an arm, *g*, engaging the pawl on the guides, substantially as and for the purpose set forth.

6. In a screw-cutting attachment for lathes, the tail-stock provided with a removable frame, *B*, having the hinged spring-arm *E*, and the guides *B'*, carrying the pivoted spring-pawl *h*, in combination with the cross-head *C*, attached to the tail-spindle, the turret-head *D*, pivoted upon said cross-head, and formed with sockets *d*, notches *d'*, and set-screws *D'*, the spring-catch *G*, recessed in one arm of the cross-head, and provided with an arm, *g*, for engagement with the pawl *h* to release the turret, the shaft *M*, attached to the rear end of the spindle, the operating-lever *M'*, pivoted on the end of said spindle, and the opposite end hinged to the frame, the set-bolt *n*, and stop-lug *n'* for limiting the motion of the cross-head, all constructed and arranged to operate substantially as and for the purpose set forth.

In testimony whereof I affix my signature in presence of two witnesses.

WILLIAM FRECH.

Witnesses:

CHAS. KRESSMANN,
WM. C. McARTHUR.